

Features

- 100A switching capability
- Single coil and double coils are available
- Optional auxiliary contact, the status of synchronous or asynchronous contact with the load end is optional
- External accessories can be customized according to user's requirements
- Surge voltage(1.2/50μs):between contact and coil 12KV
- Meets the PV Testing Standards of VDE0126
- Environment-friendly product(RoHS compliant)
- Outline Dimensions:(52.0×43.0×22.0)mm
- Main application: smart meter, compound switch, Smart home, new energy

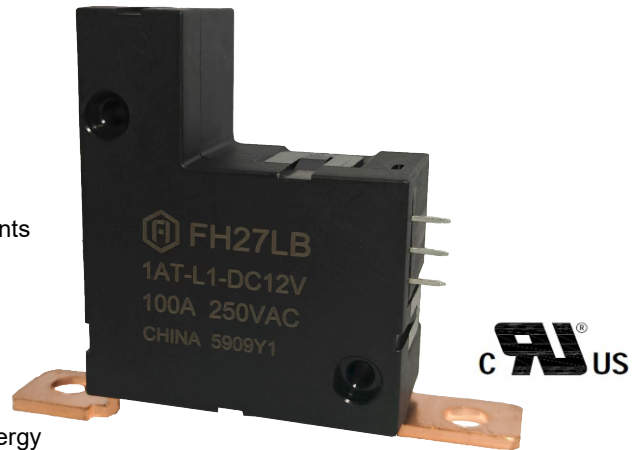

CHARACTERISTICS

Specifications	Item		
Contact Data	Contact arrangement		1A、1B
	Contact resistance(initial)		≤1.0mΩ(6VDC 1A)
	Contact material		AgSnO ₂
Rated value	Rated load(Resistance load)		100A 277VAC (Standard) 100A 415VAC
	Max.switching voltage		440VAC
	Max.switching current		120A
	Max.switching capacity		41500VA
Electrical performance	Insulation resistance(initial)		1000MΩ(500VDC)
	Dielectric strength (Initial)	Between open contacts	2000VAC 1min
		Between coil&contacts	4000VAC 1min
	Closing time		≤25ms
	Opening time		≤25ms
Creepage Distance			8mm
Inrush Voltage (1.2/50 μ s)		Between coil&contacts	12KV
Mechanical performance	Shock resistance	Functional	98m/s ² (10g)
		Destructive	980m/s ² (100g)
Vibration resistance		10Hz~55Hz 1.5mm DA	
Endurance	Mechanical		1×10 ⁶ ops
	Electrical	ON/OFF=1S/9S	100A 277VAC 1.5×10 ⁴ 次(COS φ=1)
		ON/OFF=1S/9S	100A 415VAC 1×10 ⁴ 次(COS φ=1)
		ON/OFF=10S/20S	100A 250VAC 5000ops(COS φ=1) 5000ops(COS φ=0.5)
Operate condition	Ambient temperature		-40℃~85℃
	Humidity		5%~85%RH
Termination			Plug-in needle type+Screw type(XB)
Unit weight			Approx.75g (Without attachment)
Construction			Flux proofed

Note: (1) Electrical endurance meet IEC62055-31 test requirements,do the inductive load test after the resistive load test.



COIL DATA(23°C)

Single coil latching

Nominal Voltage	Closing Voltage VDC	Opening Voltage VDC	Rated Current (±10%)	Coil Resistance (±10%)	Nominal Power	Max Voltage
DC 5V	≤3.75	≤3.75	0.6A	8.3Ω	3W	DC 7.5V
DC 6V	≤4.50	≤4.50	0.5A	12Ω		DC 9V
DC 9V	≤6.75	≤6.75	0.33A	27Ω		DC 13.5V
DC 12V	≤9.00	≤9.00	0.25A	48Ω		DC 18V
DC 24V	≤18.00	≤18.00	0.125A	192Ω		DC 36V
DC 48V	≤36.00	≤36.00	0.0625A	768Ω		DC 72V

Double coils latching

Nominal Voltage	Closing Voltage VDC	Opening Voltage VDC	Rated Current (±10%)	Coil Resistance (±10%)	Nominal Power	Max Voltage
DC 5V	≤3.75	≤3.75	1.2/1.2A	4.2/4.2Ω	6W	DC 7.5V
DC 6V	≤4.50	≤4.50	1/1A	6/6Ω		DC 9V
DC 9V	≤6.75	≤6.75	0.67/0.67A	13.5/13.5Ω		DC 13.5V
DC 12V	≤9.00	≤9.00	0.5/0.5A	24/24Ω		DC 18V
DC 24V	≤18.00	≤18.00	0.25/0.25A	96/96Ω		DC 36V
DC 48V	≤36.00	≤36.00	0.125A/0.125A	384Ω/384Ω		DC 72V

ORDERING INFORMATION

FH27LB 1B T -L1 R -XXX -DC6V

- ① Type
- ② Contact arrangement: 1A=1 open contacts
1B=1 close contacts
- ③ Contact material: T=AgSnO₂
- ④ Coil type: L1=Single coil latching, L2=Double coils latching
- ⑤ Polarity: Nil=standard polarity R=reversed polarity
- ⑥ Customer special code: numbers or letters denote customer's requirements
- ⑦ Coil specification: DC5/6/9/12/24/48V

WIRING DIAGRAM AND PC BOARD LAYOUT(Unit:mm)

Standard polarity wiring diagram

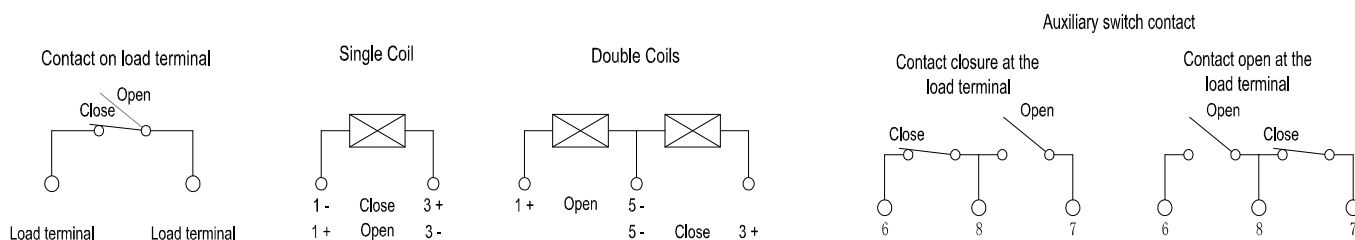

■ WIRING DIAGRAM AND PC BOARD LAYOUT(Unit:mm)

Outline Dimensions

Single Coil

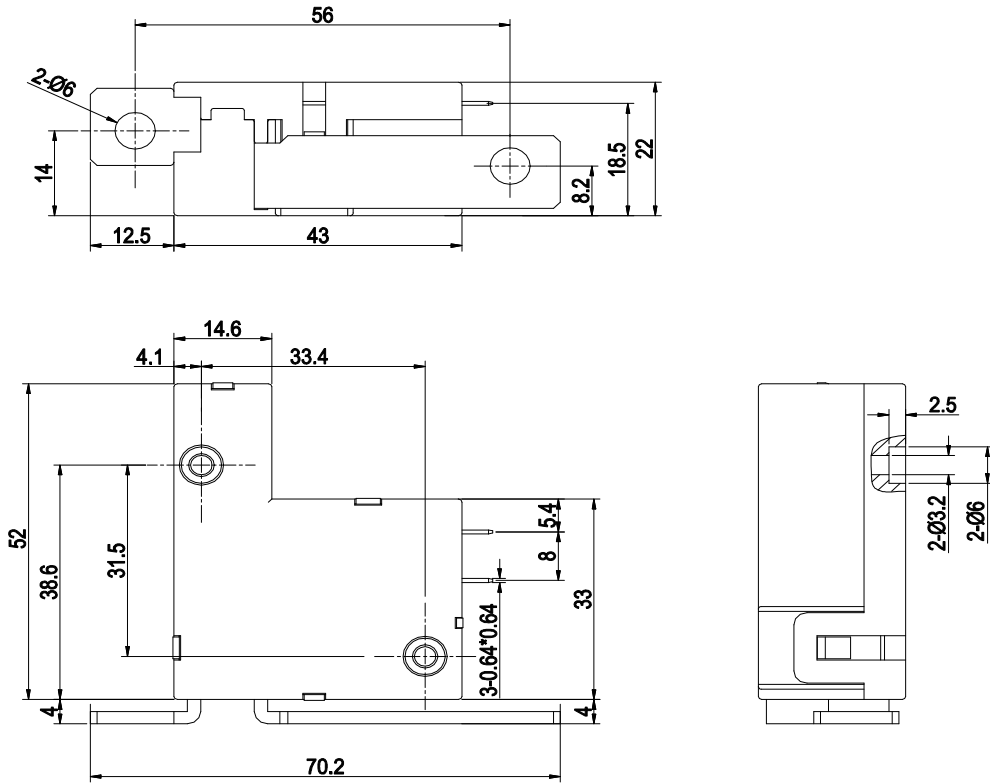

Double Coils

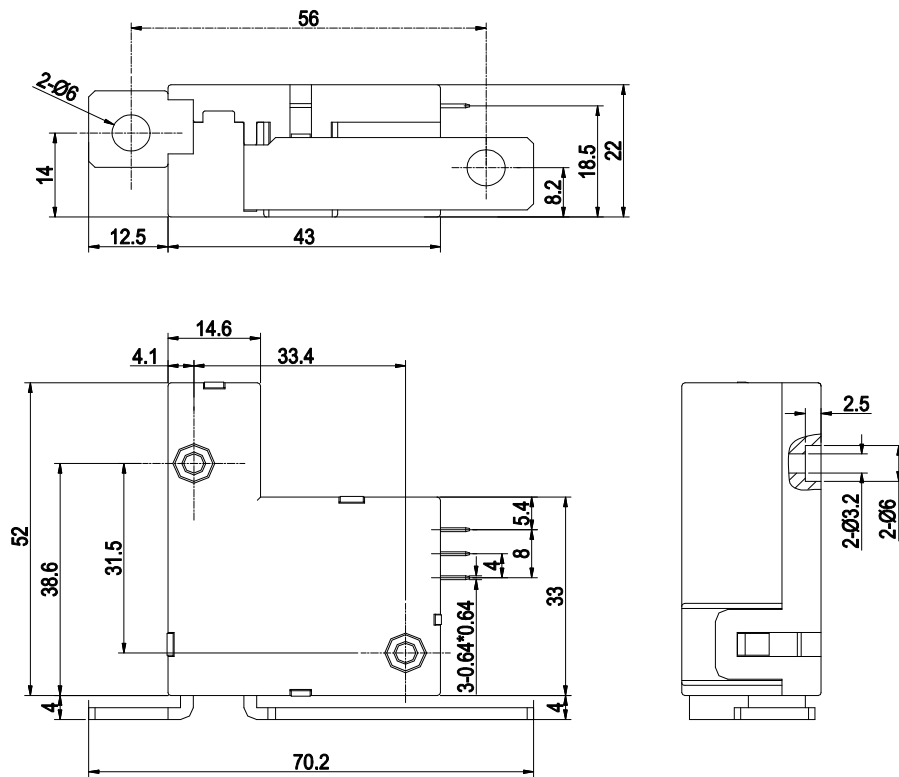

Remark:(1)In case of no tolerance shown in outline dimension:outline dimension \leq 1mm,tolerance should be \pm 0.2mm;outline dimension $>$ 1mm and $<$ 5mm,tolerance should be \pm 0.3mm;outline dimension \geq 5mm,tolerance should be \pm 0.5mm.

(2) The tolerance without indicating for PCB layout is always \pm 0.1mm.



■ TYPICAL CASES

■ SAFETY APPROVAL

Approval	File NO.
UL/C-UL	E475405

■ NOTICE

- ① For the state of latching relay as delivered, if the customer has no special requirements, we default to the closed state before delivery, but due to transportation or relay installation by shock and other factors may change the state, so please reset it to the closed or open state as needed when using;
- ② In order to maintain the initial performance parameters of the relay, please be careful not to drop the product or be affected by external force;
- ③ In order to maintain "opening" or "closing" status, energized voltage applied across the coil should reach the rated voltage, it is recommended that the actual driving voltage be 1~1.5 times the rated voltage, Pulse width $\geq 100\text{ms}$, and do not energize to "opening" coil and "closing" coil simultaneously, long energized time (more than 1 min) should also be avoided;
- ④ Normally the load terminals are not suitable for reflow solder, wave solder or tin solder, we suggest use spot welding. Load terminals shall be prevented from assembly stress;
- ⑤ Latching relays are customized products, the above cases are only for reference. If you have any questions, please contact Fanhar for more technical support;
- ⑥ The specification is for reference only. Specifications subject to change without notice.

