

## Features

- 100A switching capability
- Single coil and double coils are available
- External accessories such as manganese copper shunts and transformers can be ordered according to customer requirements
- Breakdown voltage (between contact and coil):4KV
- Environment-friendly product(RoHS compliant)
- Outline Dimensions:(34.8×28×16)mm
- Can be integrated design, convenient automatic installation and production
- Main application: smart meter



## CHARACTERISTICS

Specifications	Item		
Contact Data	Contact arrangement		1A, 1B
	Contact resistance(initial)		≤1.0mΩ(6VDC 1A)
	Contact material		AgSnO <sub>2</sub>
Rated value	Rated load(Resistance load)		100A 250VAC
	Max.switching voltage		250VAC
	Max.switching current		100A
	Max.switching capacity		25000VA
Electrical performance	Insulation resistance(initial)		1000MΩ(500VDC)
	Dielectric strength (Initial)	Between open contacts	1800VAC 1min
		Between coil&contacts	4000VAC 1min
	Operate time		≤20ms
	Release time		≤20ms
Mechanical performance	Shock resistance	Resistance functional	98m/s <sup>2</sup> (10g)
		Destructive	980m/s <sup>2</sup> (100g)
	Vibration resistance		10Hz~55Hz 1.5mm DA
Endurance	Mechanical		1×10 <sup>5</sup> ops
	Electrical	ON/OFF=1S/9S	100 250VAC 1×10 <sup>4</sup> ops(COS φ =1)
Operate condition	Ambient temperature		-40℃~85℃
	Humidity		5%~85%RH
Termination			PCB, Screw type(XB)
Unit weight			Approx.35g(Without attachment)
Construction			Flux proofed

## COIL DATA(23°C)

### Single coil latching

Nominal Voltage	Closing Voltage VDC	Opening Voltage VDC	Rated Current (±10%)	Coil Resistance (±10%)	Nominal Power	Max Voltage
DC 6V	≤4.50	≤4.50	0.25A	24Ω	1.5W	DC 9V
DC 9V	≤6.75	≤6.75	0.17A	54Ω		DC 13.5V
DC 12V	≤9.00	≤9.00	0.125A	96Ω		DC 18V
DC 24V	≤18.00	≤18.00	0.06A	384Ω		DC 36V

### Double coils latching

Nominal Voltage	Closing Voltage VDC	Opening Voltage VDC	Rated Current (±10%)	Coil Resistance (±10%)	Nominal Power	Max Voltage
DC 6V	≤4.50	≤4.50	0.5/0.5A	12/12Ω	3.0W	DC 9V
DC 9V	≤6.75	≤6.75	0.33/0.33A	27/27Ω		DC 13.5V
DC 12V	≤9.00	≤9.00	0.25/0.25A	48/48Ω		DC 18V
DC 24V	≤18.00	≤18.00	0.125/0.125A	192/192Ω		DC 36V

## ORDERING INFORMATION

**FH41LA -1B 1 T -L1 R -XXX -DC6V**

- ① Type
- ② Contact arrangement: 1A=1 open contacts, 1B=1 close contacts
- ③ PCB mounting: 1=A type, 7=Customized Accessories
- ④ Contact material: T=AgSnO<sub>2</sub>
- ⑤ Coil type: L1=Single coil latching, L2=Double coils latching
- ⑥ Polarity: Nil=Standard polarity R=Reversed polarity
- ⑦ Customer special code: numbers or letters denote customer's requirements
- ⑧ Coil specification: DC6/9/12/24V

## WIRING DIAGRAM AND PC BOARD LAYOUT(Unit:mm)

Standard polarity wiring diagram

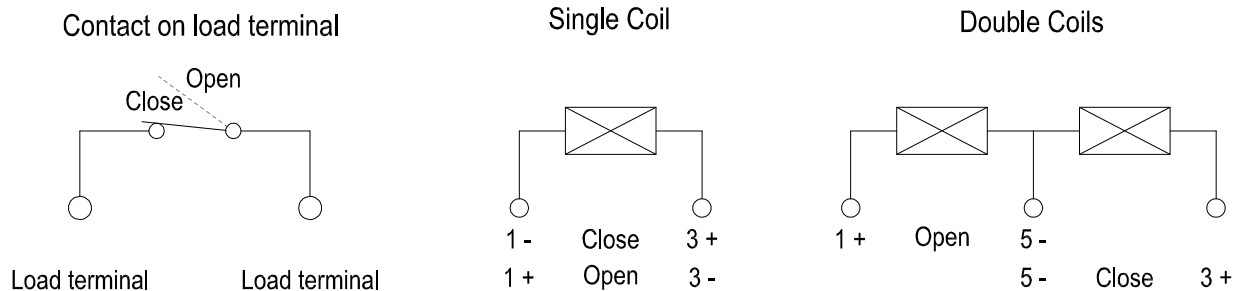

## ■ WIRING DIAGRAM AND PC BOARD LAYOUT(Unit:mm)

### Outside drawing

A type single coil

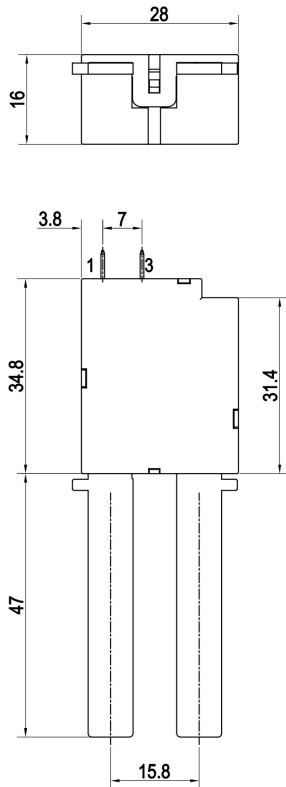

A type double coils

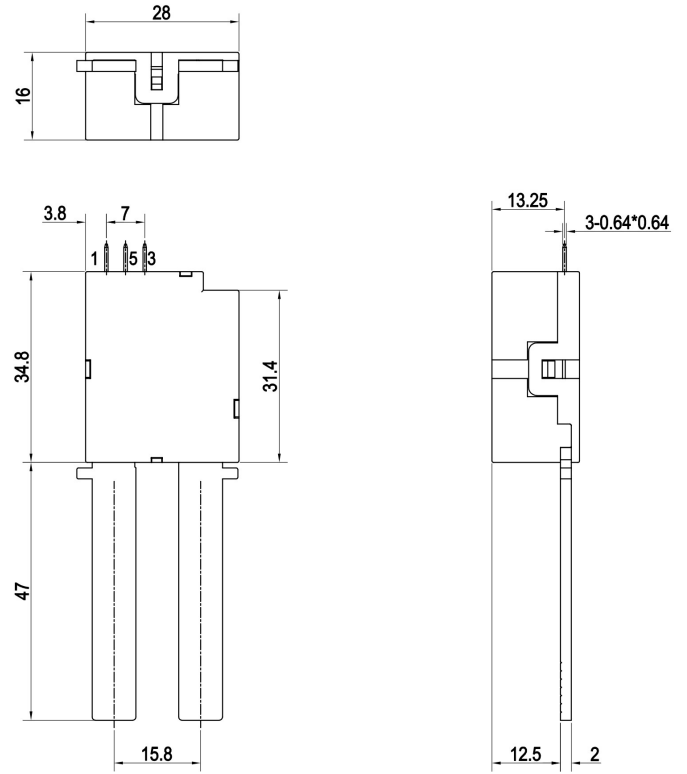

Remark:(1)In case of no tolerance shown in outline dimension:outline dimension $\leq$ 1mm,tolerance should be $\pm$ 0.2mm;outline dimension  $>$ 1mm and  $<$ 5mm,tolerance should be  $\pm$ 0.3mm;outline dimension $\geq$ 5mm,tolerance should be  $\pm$ 0.5mm.

(2) The tolerance without indicating for PCB layout is always  $\pm$ 0.1mm.

## ■ TYPICAL CASES



## ■ NOTICE

- ① For the state of latching relay as delivered,If the customer has no special requirements, we default to the closed state before delivery,but due to transportation or relay installation by shock and other factors may change the state,so please reset it to the closed or open state as needed when using;
- ② In order to maintain the initial performance parameters of the relay, please be careful not to drop the product or be affected by external force;;
- ③ In order to maintain "opening" or "closing" status,energized voltage applied across the coil should reach the rated voltage,it is recommended that the actual driving voltage be 1~1.5 times the rated voltage, Pulse width  $\geq 50\text{ms}$ ,and do not energize to "opening" coil and "closing" coil simultaneously,long energized time(more than 1 min) should also be avoided;
- ④ Normally the load terminals are not suitable for reflow solder, wave solder or tin solder, we suggest use spot welding. Load terminals shall be prevented from assembly stress;
- ⑤ Latching relays are customized products,the above cases are only for reference. If you have any questions, please contact Fanhar for more technical support;
- ⑥ The specification is for reference only.Specifications subject to change without notice.

